

THIS DRAWING IS UNPUBLISHED. RELEASED FOR PUBLICATION
 © COPYRIGHT BY TYCO ELECTRONICS CORPORATION. ALL RIGHTS RESERVED.

LOC	DIST	REVISIONS					
FT	0	P	LTR	DESCRIPTION	DATE	DWN	APVD
			Z1	REVISED PER ECO-05-4934	7/21/05	SS	GS

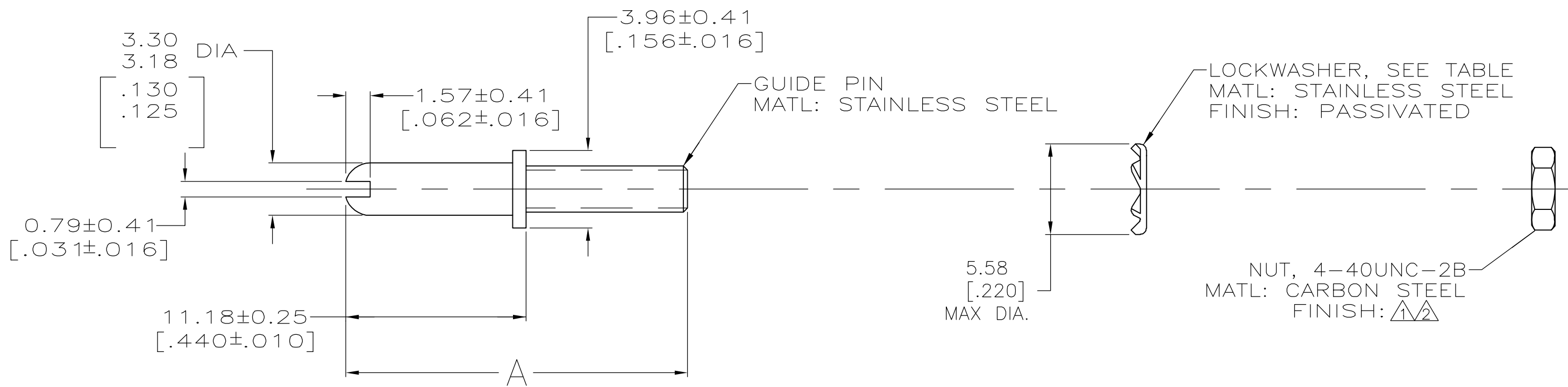

OBSOLETE	$\Delta 2$	STANDARD	EXTERNAL TOOTH	21.08±0.25 [.830±.010]	1-200833-1
	$\Delta 1$	SMALL PACK	EXTERNAL TOOTH	21.08±0.25 [.830±.010]	1-200833-0
	-	STANDARD	SPLIT	24.13-24.51 [.950-.965]	200833-8
	$\Delta 1$	STANDARD	EXTERNAL TOOTH	21.08±0.25 [.830±.010]	200833-2
NUT FINISH	PACKAGING TYPE	LOCKWASHER TYPE	A		PART NUMBER

NOTES:
 $\Delta 1$ ZINC PLATE WITH HEXAVALENT CHROMIUM.
 $\Delta 2$ ZINC PLATE WITH NON-HEXAVALENT CHROMIUM.

THIS DRAWING IS A CONTROLLED DOCUMENT.

DIMENSIONS: mm [INCHES]	TOLERANCES UNLESS OTHERWISE SPECIFIED:	DWN D.GELTZ 04/19/93	 Tyco Electronics Corporation Harrisburg, Pa 17105-3608
	0 PLC ± - 1 PLC ± - 2 PLC ± - 3 PLC ± - 4 PLC ± - ANGLES ± -	CHK R.STONE 4-23-93	
MATERIAL SEE CALLOUTS	FINISH SEE CALLOUTS	APVD -	NAME GUIDE PIN KIT, UNASSEMBLED, CORNER, MINIATURE RECTANGULAR, M SERIES
		PRODUCT SPEC -	SIZE A3
		APPLICATION SPEC -	CAGE CODE 00779
		WEIGHT -	DRAWING NO G-200833
		CUSTOMER DRAWING	RESTRICTED TO -
		SCALE 4:1	SHEET 1 OF 1
		REV Z1	